

Securelok™

Wheel Nuts

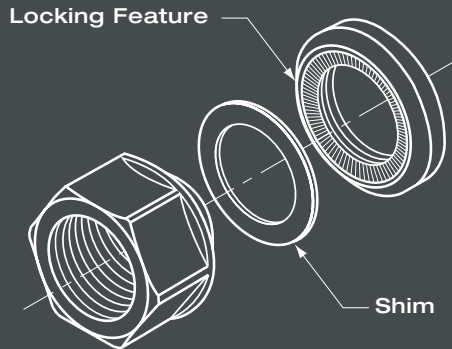

- **Installation torque same as current nuts**
- **Ramped nut/washer interface resists vibration-induced back off**
- **Maintains high clamp load values**
- **Branded for integrity**

MacLean Vehicle Systems
MVS®
A MacLean-Fogg Company

Securelok™ wheel nuts utilize a ramp system

Vibration can cause the most secure joints to loosen, as can frequent severe braking. Typical solutions include increasing application torque, thread interference or a mechanical method of “locking” the nut to the joint.



Securelok™ from MVS combines the best of two solutions; consistent torque/tension and formed ramps-and-valleys on the nut-washer interface.

Application torque requirements for Securelok are in the same range as current wheel fasteners (450 to 500 lbs/ft. of torque). Resulting joint tension values exceed 45,000 pounds clamp force in laboratory testing.

Joint integrity assured

The solution involves requiring the nut to increase joint tension in order to reverse, or back off. During application, the fastener “settles” into a valley between two high spots (ramps). To back off, the nut must rise over a high spot. Laboratory testing shows reversal torque values approaching 80 per cent of those required during installation.

Securelok will address issues associated with severe operating conditions, such as those experienced with excessive brake torque on vocational type vehicles.

Fatigue, salt spray testing complete

M22 size Securelok wheel nuts have completed vigorous fatigue and vibration-resistance testing, as well as long-term salt spray exposure. Ask for your copy of the results of our tests for Torque/Tension, vibration analysis and salt spray performance.

For the full story on Securelok two-piece wheel nuts with the machined ramps-and-valleys, and how their use can save your fleet (or manufacturing operation) significant dollars, log on to www.mfmvs.com, call us at 1-800-323-4536 or contact your MVS sales representative.

Securelok™

Wheel Nuts

Wheel fasteners have their ups and downs.

Vibration testing of Securelok using state-of-the-art apparatus (Junkers) yielded remarkable results. Unlike traditional fasteners that exhibit a continual loss of clamp force over the entire test period Securelok performs as expected.

After a slight initial adjustment in clamp force (that still delivers exceptional joint tension) Securelok clamp force remains virtually unchanged for the remainder of the test period.

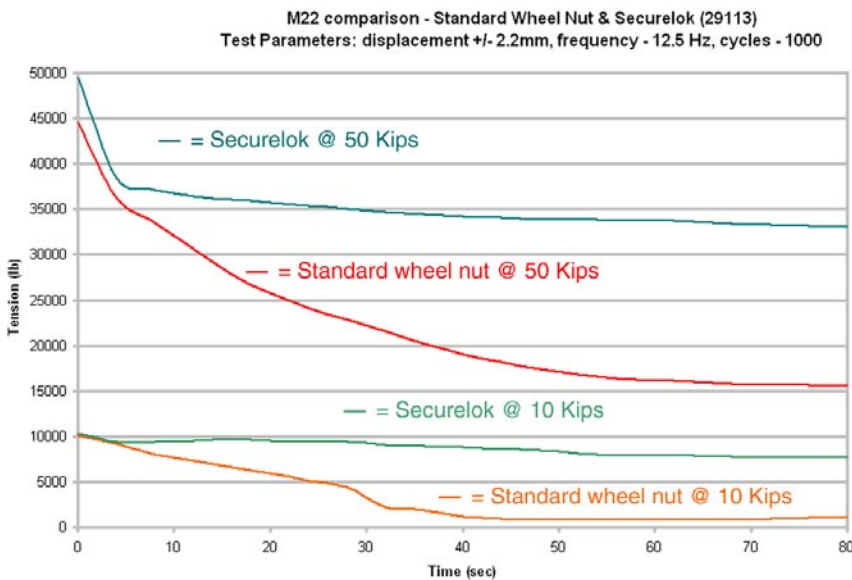

Torque wrench installation

Features

- + Installation torque same as current nuts
- + Ramped nut/washer interface resists vibration-induced back off
- + High clamp load values maintained
- + PTFE corrosion-resistant coating
- + Formed wheel-mating surface
- + Branded for integrity

Benefits

- + Labor cost savings
- + Lower maintenance costs
- + Wheel/hub wear-and-tear reduced
- + Reduces maintenance time
- + Lowers parts costs
- + Minimizes wheel damage
- + Peace of mind



MacLean Vehicle Systems
1000 Allanson Road, Mundelein, IL 60060
847-566-0010 | Fax: 847-970-4621

www.mfmvs.com

© Copyright 2005, MacLean Vehicle Systems. All rights reserved.